

Typical Features

- ◆ Wide input voltage range 2 : 1
- ◆ Efficiency up to 90%
- ◆ Low no-load power consumption
- ◆ Operating Temperature from -40°C to +85°C
- ◆ High isolation voltage 1500VDC (input-output)
- ◆ Input under voltage protection, output over current, over voltage, over temperature & short circuit protections
- ◆ Standard 1/8 brick size

ZDD100-48S05 is a high-performance DC-DC converter specially designed for communication field, Its rated input voltage 48VDC (full range from 36V to 75VDC), regulated single output 5V/100W without minimum load limit. It has the multi-function of input under voltage protection, output over current, over voltage, over temperature and short circuit protections, input ON/OFF control, output voltage distal end compensation and output voltage Trim, etc.

Selection Guide

Part No.	Input Voltage Range (VDC)	Output Power (W)	Output Voltage (VDC)	Output Current (A)	Ripple & Noise (mVp-p)	Full Load Efficiency (%) Min/Typ.	Remarks
ZDD100-48S05C	36 - 75	100	5	20	100	88/90	Standard Positive logic
ZDD100-48S05N							Standard Negative logic
ZDD100-48S05C-H							With Heatsink Positive logic
ZDD100-48S05N-H							With Heatsink Negative Logic

Input Specifications

Item	Operating conditions	Min.	Typ.	Max.	Unit	
Max input current	Input voltage 36V, full load	--	--	4	A	
No load input current	Nominal input voltage	--	--	20	mA	
Standby input current	Nominal input voltage, CNT Control OFF	--	--	3	mA	
Input inrush voltage (1sec. max.)	The unit could be permanently damaged by input over this Voltage	-0.7	--	85	VDC	
Start-up voltage		--	--	36		
Input under voltage protection	With No-load (over current protection will work in advance at full load)	31	--	34		
ON/OFF Control (CNT)	Positive logic: CNT no connection or connected to 3.5-15V to turn ON, connected to 0-1.2V to turn OFF the converter					Reference voltage -Vin
	Negative logic: CNT no connection or connected to 3.5-15V to turn OFF, connected to 0-1.2V to turn ON the converter					

Output Specifications					
Item	Operating conditions	Min.	Typ.	Max.	Unit
Output Voltage Trim Range	Nominal Input Voltage	5	--	5.15	V
Output voltage accuracy	Nominal Vin, 10%-100% Load	--	±0.2	±1.0	%
Line regulation	Full load, input voltage from low to high	--	±0.2	±0.5	
Load regulation	Nominal input voltage, 10%-100% load	--	±0.2	±0.5	
Transient recovery time	25% load step change (step rate 1A/50uS)	--	200	250	uS
Transient response deviation		-5	--	+5	%
Temperature drift coefficient	Full load	-0.02	--	+0.02	%/°C
Ripple & Noise	20MHz bandwidth, with external capacitor >1000µF	--	80	100	mVp-p
Turn on delay time		--	50	100	mS
Output start-up time	Nominal input voltage, output capacitor above 1000µF	--	70	100	mS
Output voltage adjustment (TRIM)		-10	--	+10	%
Output voltage distal end compensation (Sense)		--	--	5	%
Over temperature protection	Internal temperature sensor detecting	105	115	125	°C
Over current protection		22	--	28	A
Short circuit protection		Hiccup, continuous, self-recovery			

General Specifications						
Item	Operating conditions		Min.	Typ.	Max.	Unit
Isolation voltage	I/P-O/P	Test 1min, leakage current <3mA	1500	--	--	VDC
	I/P-FG	Test 1min, leakage current <3mA	1500	--	--	VDC
	O/P-FG	Test 1min, leakage current <3mA	500	--	--	VDC
Insulation resistance	I/P-O/P	@ 500VDC	100	--	--	MΩ
Switching frequency			--	230	--	KHz
MTBF			150	--	--	K hours

Environmental characteristics						
Item	Operating conditions		Min.	Typ.	Max.	Unit
Operating temperature	Refer to the temperature derating graph		-40	--	+105	°C
Storage humidity	No condensing		5	--	95	%RH
Storage temperature			-40	--	+125	°C
Pin soldering temperature	Soldering time <1.5S		--	--	+350	
Cooling requirement			EN60068-2-1			
Dry heat requirement			EN60068-2-2			

Damp heat requirement		EN60068-2-30
Shock and vibration		IEC/EN 61373 C1/Body Mounted Class B

EMC Performances

EMI	CE	EN55032-3-2	150kHz-500kHz 66dBuV	
		EN55032-2-1	500kHz-30MHz 60dBuV	
	RE	EN55032-3-2	30MHz-230MHz 50dBuV/m at 3m	
		EN55032-2-1	230MHz-1GHz 57dBuV/m at 3m	
EMS	ESD	IEC/EN61000-4-2	Contact ±6KV/Air ±8KV	Perf. Criteria B
	RS	IEC/EN61000-4-3	10V/m	Perf. Criteria A
	EFT	IEC/EN61000-4-4	±2kV 5/50ns 5kHz	Perf. Criteria A
	Surge Immunity	IEC/EN61000-4-5	line to line ± 1KV (42Ω, 0.5μF)	Perf. Criteria B
	CS	IEC/EN61000-4-6	0.15MHz-80MHz 10 Vr.m.s	Perf. Criteria A

Physical Characteristics

Case material	Metal Baseplate
Heat sink	N/A
Cooling method	Conduction cooling or forced air cooling with fan
Unit weight	Standard 27g, with Baseplate 48g

Mechanical Dimensions & Pin-out Function Description

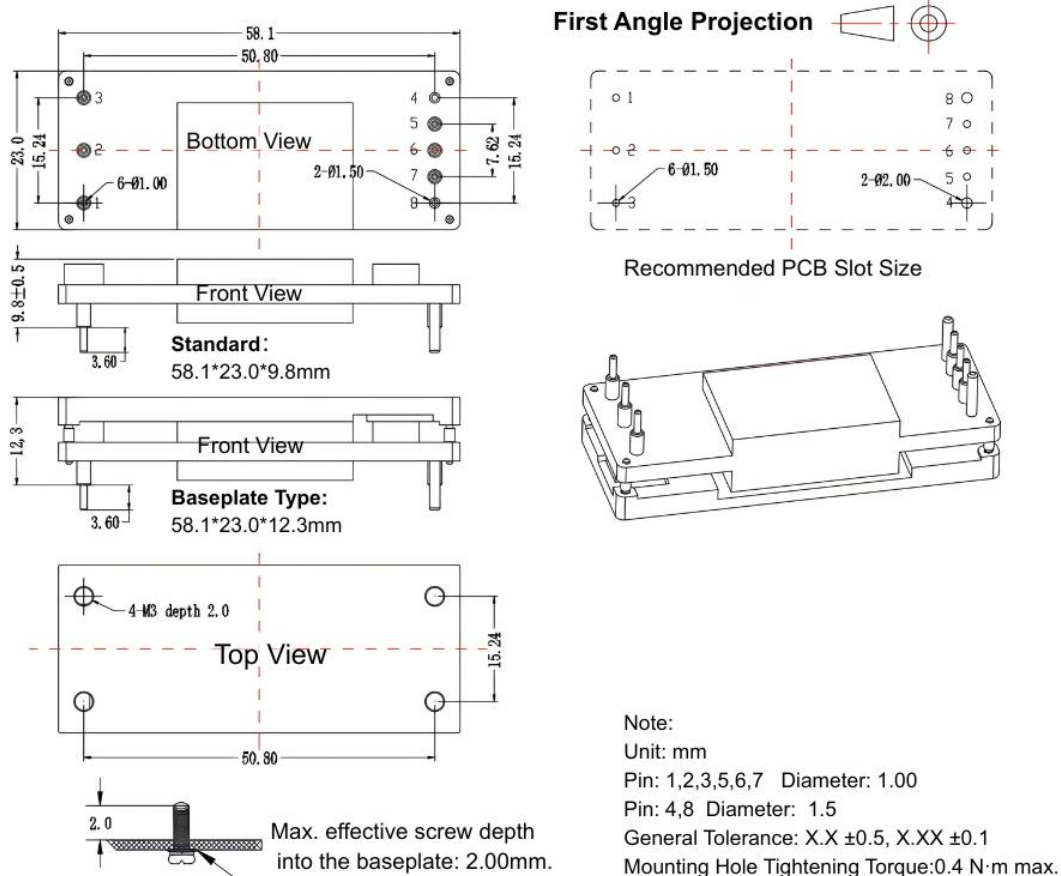

No.	1	2	3	4	5	6	7	8
Function	Vin+	CNT	Vin-	Vout-	-Sense	TRIM	+Sense	Vout+
Description	Input V+	ON/OFF Control	Input V-	Output V-	Output distal end compensation S-	Output Voltage Trim	Output distal end compensation S+	Output V+

Product Characteristics Curves

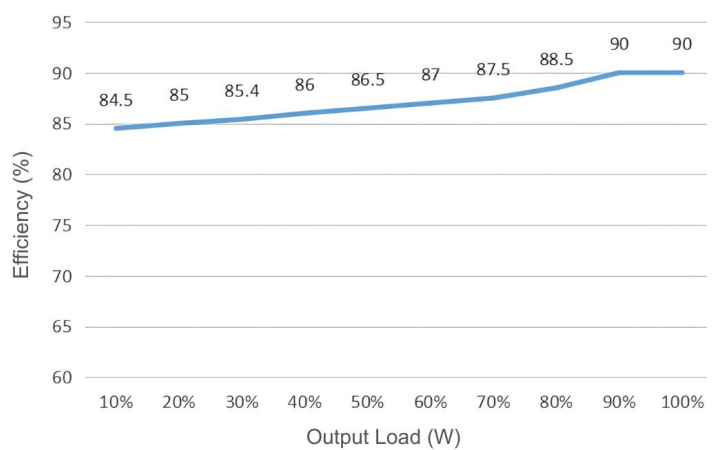
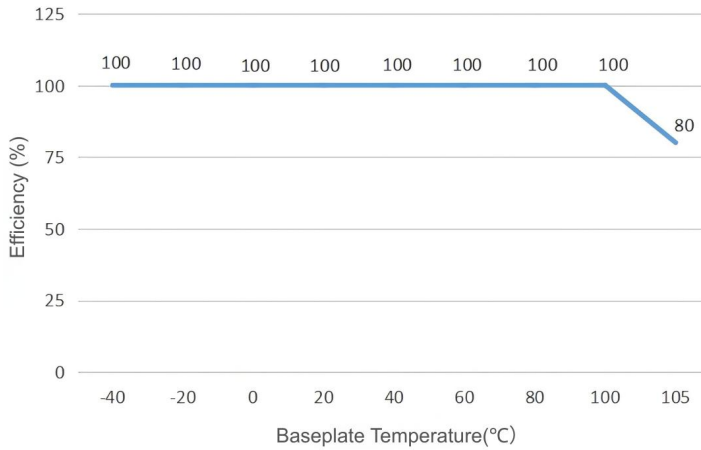

Note:
 1. The output power and the efficiency in the graphs have been tested with typical values.
 2. The data in the temperature graph have been tested at Aipu laboratory test conditions. It is recommended to keep the temperature of the PCBA not more than 100 °C when the converter operates at the rated load for the application.

Recommended Circuits for Application

1. Ripple and Noise

All this series of converters will be tested according to the circuit diagram below before shipping.

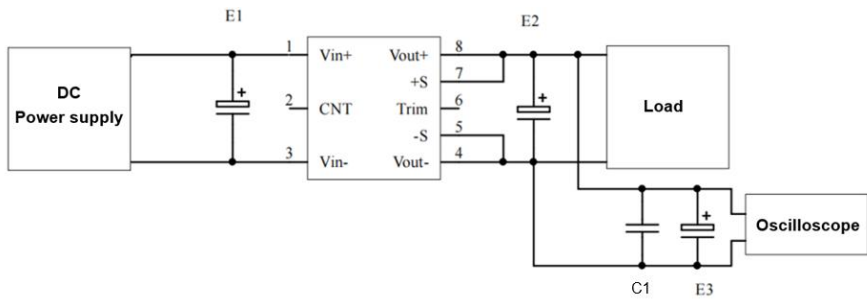

Output Volt.	Capacitance			
	E1 (μF)	E2 (μF)	C1 (μF)	E3 (μF)
3.3VDC	100	1000	1	10
5VDC		680		
12VDC		220		
.....	68	68	1	10
48VDC		68		
110VDC		68		

2. Typical application circuit diagram

If this circuit recommended is not adopted, please connect an electrolytic capacitor ≥100 μF in parallel at the input to suppress the possible surge voltage.

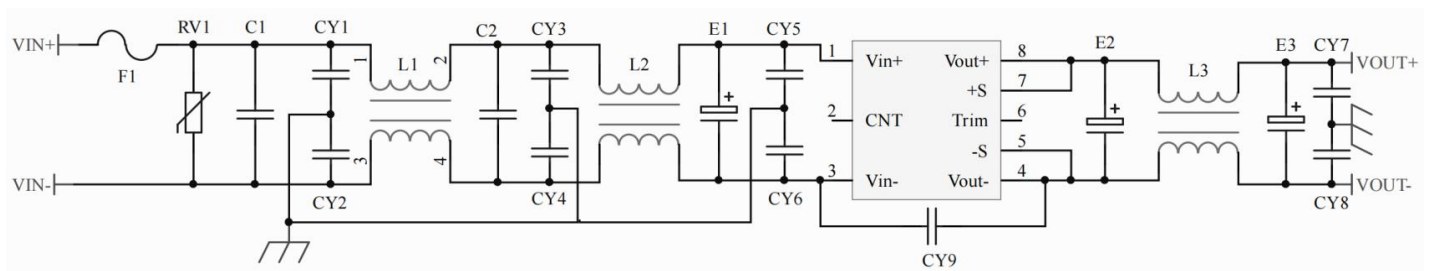

F1	T10A/250V Time-delay fuse
RV1	14D 100V Varistor

C1, C2	105/100V Polyester Film Capacitor
CY1, CY2, CY3, CY4, CY5, CY6	102/250Vac Y2 capacitor
CY7, CY8	103/2KV Ceramic Capacitor
CY9	471/250Vac Y2 capacitor
E1	100μF/100V Electrolytic Capacitor
E2, E3	470μF/10V Low ESR Capacitor
L1, L2	>5mH, temperature rise less than 25°@4A
L3	>100uH, temperature rise less than 25°@20A

3. ON/OFF control (CNT) application

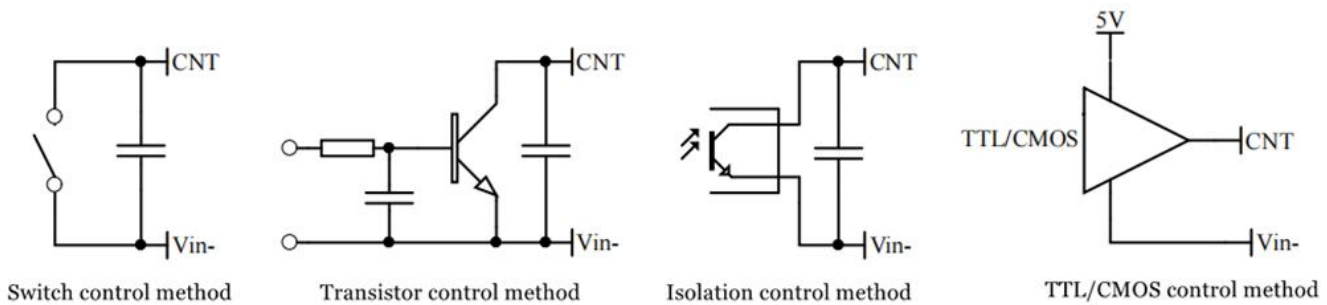

4. Application for Sense

1)With NO distal end compensation

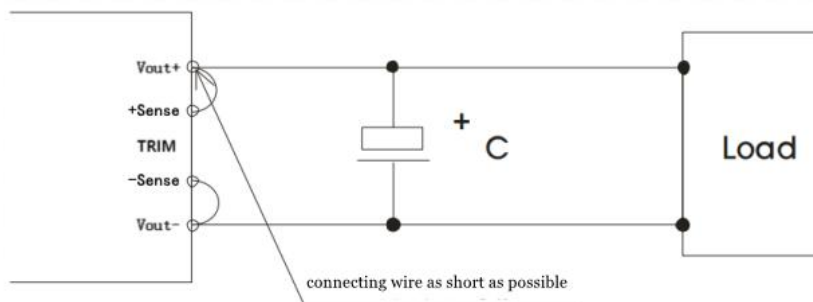

Notes:

1. Vout+ & Sense+, Vout- & Sense- should be shorted when distal compensation is not needed
2. The lead wire between Vout+ and Sense+, Vout- and Sense- should be as short as possible, and close to the pins, or else the output may be unstable.

2)With distal end compensation

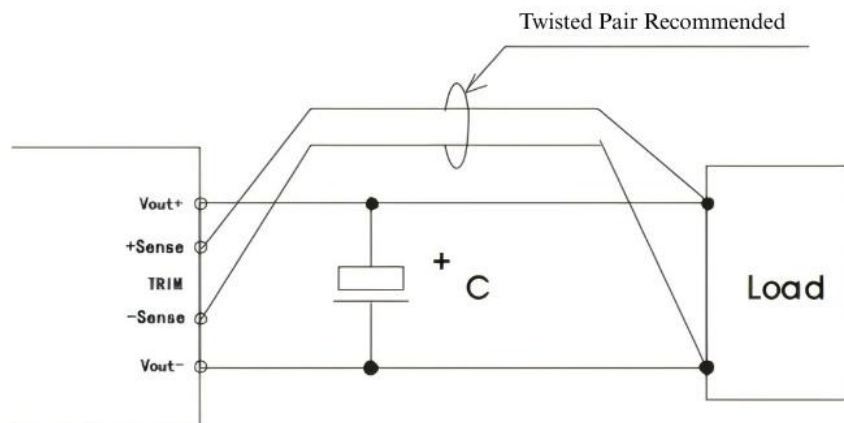

Notes:

1. The output voltage may be unstable if the compensation cables are too long.
2. The Twisted pair or shielded cables are recommended, the cable length should be as short as possible.
3. Wide copper path on PCB or thick lead wires between the power supply and the load should be used to achieve the line voltage drop <0.3V. The target is to keep output voltage within the specified range.
4. The leads wire resistance may create the output voltage oscillation or larger ripples. Please verify it before to use.

5. TRIM Function and Resistance Calculation

The relationship between the output voltage change (ΔU) and the Trim resistors(R_{up}/R_{down}) is as follows:

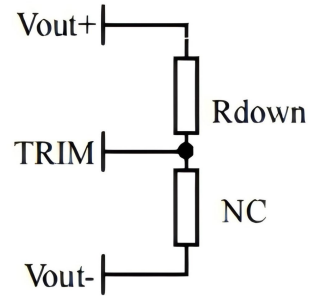
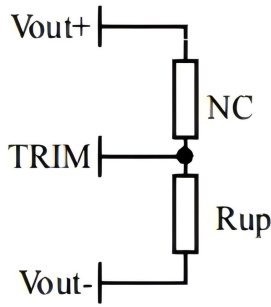

Voltage Increase (Trim Up)

Add resistor R_{up} between TRIM and Vout- (to increase output voltage)

$$R_{up} = \frac{12.75}{\Delta U} - 5.1 \text{ (k}\Omega\text{)}$$

Voltage Decrease (Trim Down)

Add resistor R_{down} between TRIM and Vout+ (to decrease output voltage)

$$R_{down} = \frac{10.2 \times (3.75 - \Delta U)}{\Delta U} - 5.1 \text{ (k}\Omega\text{)}$$

6. This converter is not available to be connected in parallel for the output power increasing. Please contact Aipu technician for this kind of application requirement.

Additional Information

1. The product warranty period is two years. The failed product can be repaired/replaced free of charge if it operates at normal condition. A paid service shall be also provided if the product fails after operating under wrong or unreasonable conditions.
2. Aipupower can provide customization design and filter modules for matching, please contact our technician for details.
3. Revision Date: 2026-02-26

Guangzhou Aipu Electron Technology Co., Ltd

Address: Building 4, HEDY Park, No.63, Punan Road, Huangpu Dist, Guangzhou, China.

Tel: 86-20-84206763 Fax: 86-20-84206762 HOTLINE: 400-889-8821

E-mail: sales@aipu-elec.com Website: www.aipupower.com